

These space heaters are used for hundreds of industrial applications. Our customers mostly use them to stop moisture and condensation in electric panels and electric motors. The stainless steel sheaths make them durable in a rugged industrial application. We are able to supply according to customer needs and specification.

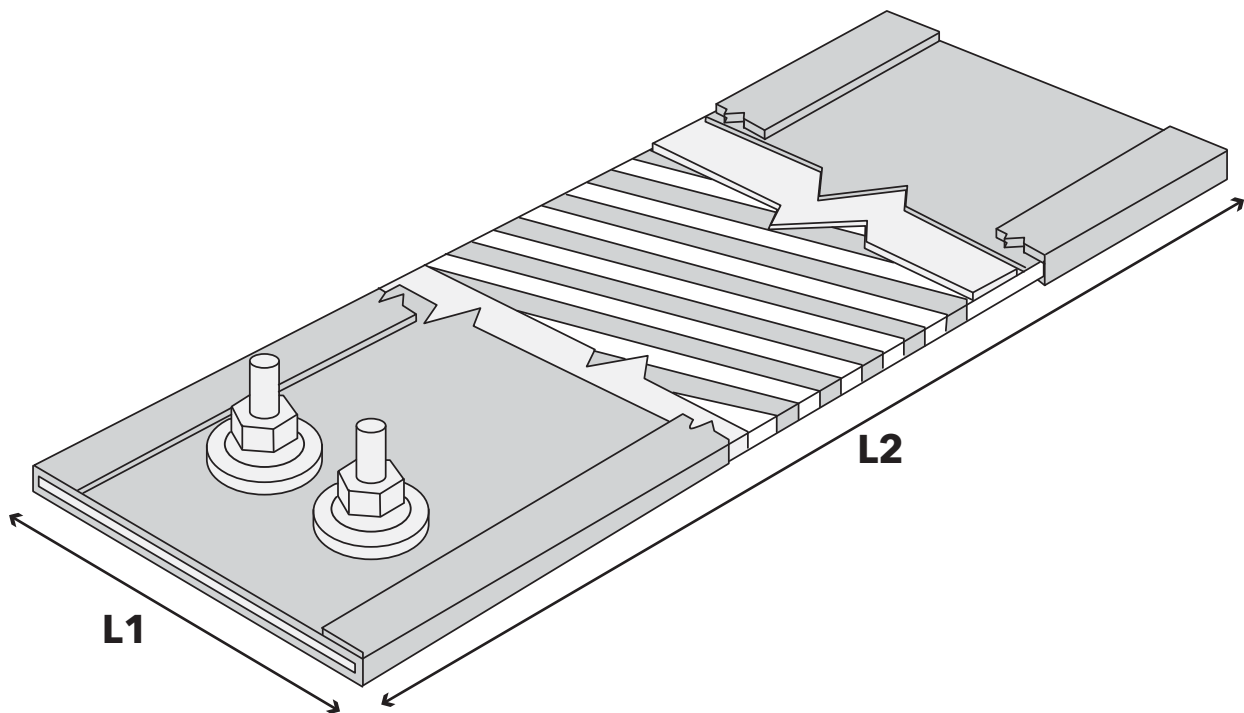

Specifications:

- M5 Threaded Terminals
- Mica Insulation
- Stainless Steel Sheath
- Wound Resistance Ribbon

Supply voltage available: 110V, 220V
Wattage: 50 – 300 watts

On ordering please state the L1 and L2 voltage and wattage e.g. 220 Volts / 250 Watts